

Non Contact Magnetic Safety Switches

Data Sheet Magnetic Series

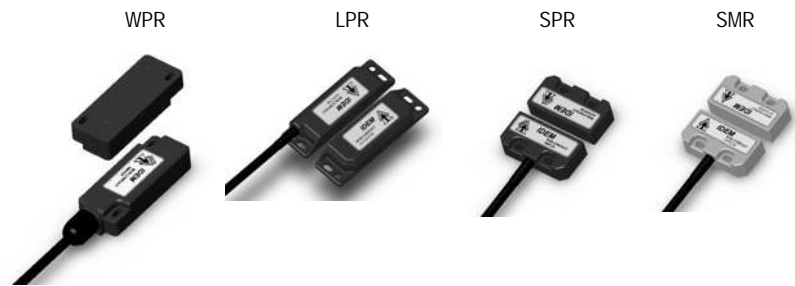

Using Magnetic Non Contact Safety Interlock Switches

Application:

IDEM Magnetic Non Contact switches are designed to interlock hinge, sliding or removal guard doors. They are specifically advantageous when :

- a) poor guard alignment exists
- b) high hygiene requirements exist e.g. food industry hose down
- c) a long mechanical life is required (no moving or touching parts).

When used In combination with approved Dual Channel Safety Modules, IDEM Coded Non Contact Switches can be used to provide up to EN954-1 Category 4.

Operation:

All IDEM Magnetic Non Contact Safety Switches are designed to conform to IEC 947-5-3 and be used as directed by EN1088, EN 292 and EN 60204-1. They have a magnetic sensing system which provides a wide (>10mm) sensing distance and provides a high tolerance to misalignment after sensing. They can be fitted behind stainless steel fittings and can operate from 4 directions even in extreme environments of temperature and moisture.

Installation:

Installation of all IDEM Non Contact Switches must be in accordance with a risk assessment for the individual application.

The use of a Safety module is recommended for monitoring IDEM Magnetic switches. These controllers monitor 2 redundant circuits as per EN 954-1 for up to Category 4 protection. IDEM Magnetic switches are designed to operate with most Dual Channel Safety Modules to satisfy IEC 947-5-3 PDF-M.

M4 mounting bolts must be used to fix the switches. Tightening torque for mounting bolts to ensure reliable fixing is 1.0 Nm. Always mount on to Non Ferrous materials. The recommended setting gap is 5mm. The Safety switch must not be used as a mechanical stop or be adjusted by striking with a hammer. The actuator must not be allowed to strike the switch. Do not mount adjacent switches or actuators closer than 30mm.

Typical misalignment tolerance after setting is 5mm in any plane.

After installation always check each switch function by opening and closing each guard individually in turn and ensuring that the LED's on the Safety Modules are illuminated when the switch is closed and are extinguished when the switch is open. Check that the machine stops and cannot be re-started when each switch is open. If the auxiliary circuit is not fitted or not used then cut and discard the Yellow and Green conductors.

Actuator operating directions :

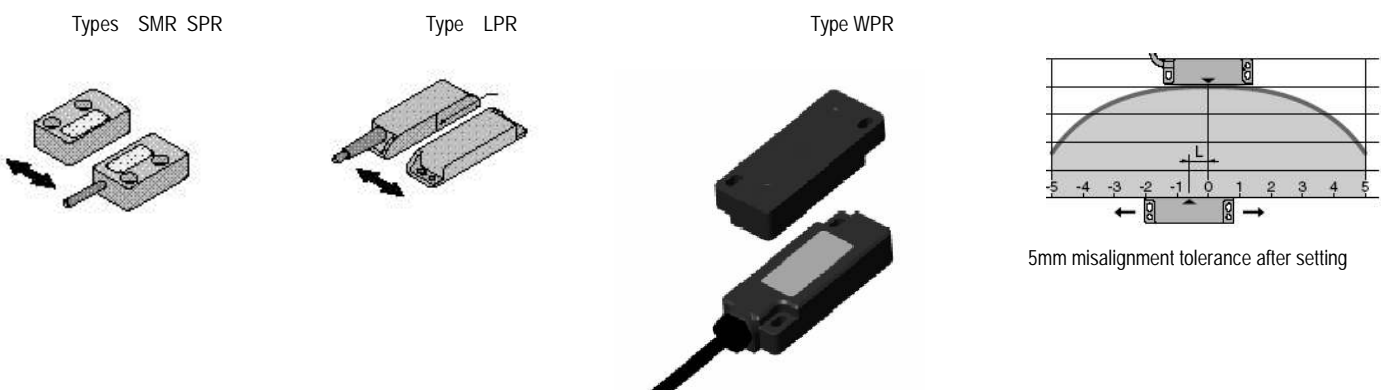

Maintenance:

Monthly: Check alignment of actuator and look for signs of mechanical damage to the switch casing. Check wiring for signs of damage.

Every 6 months: Check each switch function by opening and closing each guard individually in turn and the LED's on the Safety Modules are illuminated when the switch is closed and are extinguished when the switch is open. Check that the machine stops and cannot be re-started when each switch is open.

Never repair any switch, actuator or integral cables. Replace any switch which displays signs of mechanical damage to casing or cables.

Non Contact Magnetic Safety Switches

SP/SM

WP

LP

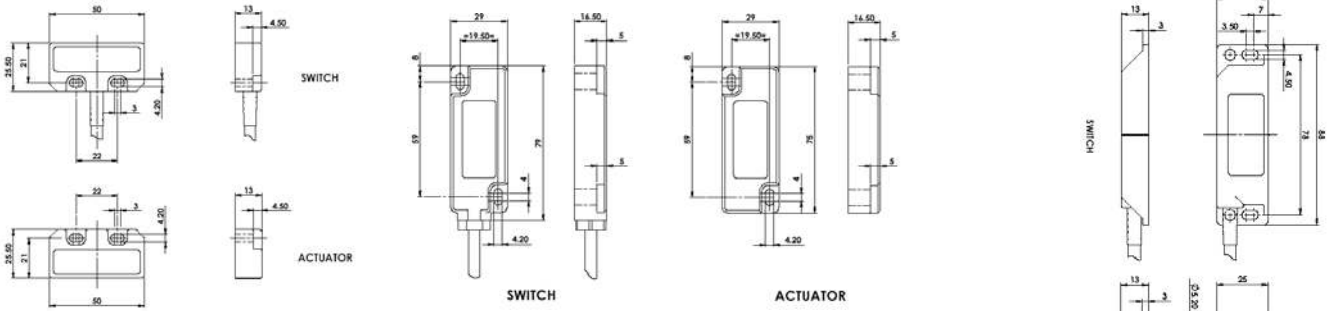

Heavy Duty WPR version - Fuse Externally 1.6 A. (F)
 Medium Duty versions – SMR / SPR / LPR versions - Fuse Externally 0.8 A. (F)

PDF-M IEC 947-5-3

Wiring Examples (shown with IDEM SCR2/3 Controllers):

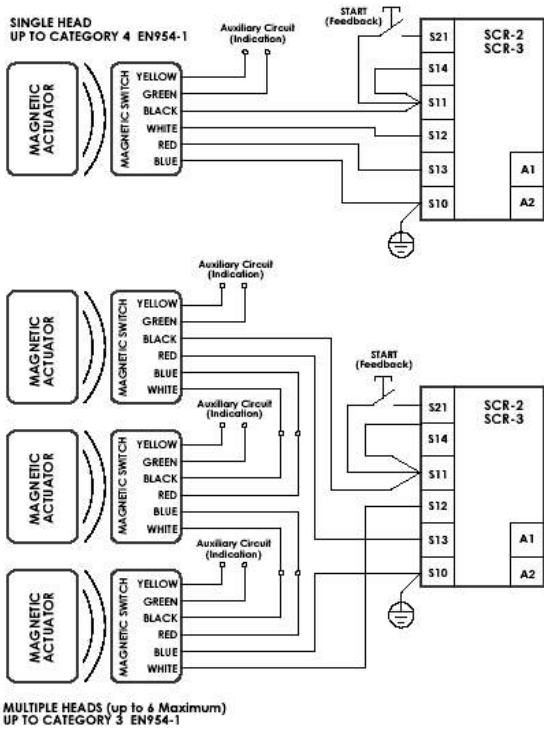

MULTIPLE HEADS (up to 4 Maximum)
 UP TO CATEGORY 3 EN954-1

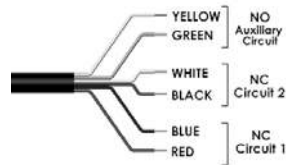

Standards EN1088 IEC 947-5-3 EN 60204-1
 EN 954-1 UL508

Type: SP LP SM
 Safety Channel 1 NC Voltage free : 250V.ac 1.0 A Max.
 Safety Channel 2 NC Voltage free : 250V.ac 1.0 A Max.
 Auxiliary Channel 3 NO Voltage free : 24V.dc 0.2 A Max.

Type: WP
 Safety Channel 1 NC Voltage free : 250V.ac 2.0 A Max.
 Safety Channel 2 NC Voltage free : 250V.ac 2.0 A Max.
 Auxiliary Channel 3 NO Voltage free : 24V.dc 0.2 A Max.

Fuses (NC Circuits) Types: SP LP SM
 Internal 1.0 A. (F) Fuse externally 0.8A (F)
 Type: WP
 Internal 2.0 A. (F) Fuse externally 1.6A (F)

- Contact release time <2ms
- Initial contact resistance <500 milliohm
- Minimum switched current 10V. dc 1mA
- Dielectric withstand 250V.ac
- Insulation Resistance 100 Mohms
- Recommended setting gap 5mm
- Switching Distance: (Target to target) Sao 10mm Close Sar 22mm Open
- Tolerance to misalignment 5mm in any direction from 5mm setting gap
- Switching frequency 1.0 Hz maximum
- Approach speed 200mm/m. to 1000mm/s.
- Body Material Red Polyester or Stainless Steel 316 -25 / 80C. (105C. Stainless Steel).
- Enclosure Protection IP67
- Shock Resistance IEC 68-2-27 11ms 30g
- Vibration Resistance IEC 68-2-6 10-55 Hz. 1mm
- Mechanical Life Expectancy 10,000,000 switchings
- Electrical Life Expectancy 1,000,000 switchings

Cable Type PVC 6 or 8 core 6mm O.D.
 Mounting Bolts 2 x M4 Tightening torque 1.0 Nm

Sales No.		Cable / Circuits	Sales No.		Cable / Circuits	Sales No.		Cable / Circuits	Sales No.		Cable / Circuits
111009	SPR	2M 2NC	110009	LPR	2M 2NC	139009	SMR	2M 2NC	112001	WPR	2M 2NC
111010	SPR	5M 2NC	110010	LPR	5M 2NC	139010	SMR	5M 2NC	112002	WPR	5M 2NC
111011	SPR	10M 2NC	110011	LPR	10M 2NC	139011	SMR	10M 2NC	112003	WPR	10M 2NC
111012	SPR	QD-M12 2NC	110012	LPR	QD-M12 2NC	139012	SMR	QD-M12 2NC	112004	WPR	QD-M12 2NC
111013	SPR	2M 2NC 1NO	110013	LPR	2M 2NC 1NO	139013	SMR	2M 2NC 1NO	112005	WPR	2M 2NC 1NO
111014	SPR	5M 2NC 1NO	110014	LPR	5M 2NC 1NO	130914	SMR	5M 2NC 1NO	112006	WPR	5M 2NC 1NO
111015	SPR	10M 2NC 1NO	110015	LPR	10M 2NC 1NO	139015	SMR	10M 2NC 1NO	112007	WPR	10M 2NC 1NO
111016	SPR	QD-M12 2NC 1NO	110016	LPR	QD-M12 2NC 1NO	139016	SMR	QD-M12 2NC 1NO	112008	WPR	QD-M12 2NC 1NO

CE Declaration of Conformity.

These Products conform to the Essential Health and Safety Requirements of the European Machinery Directive (98/37/EC) and the Essential Protection Requirements of the EMC Directive (89/336/EEC).

Supplied under RoHS Directive 02/95/EC.

Nov 06